

FLAGSHIP MARINE, INC.				
REV.	ZONE	DESCRIPTION	DATE	ENG APPROVAL
01	-	INITIAL CHECK-IN	7/20/2011	-

D  
C  
B  
A

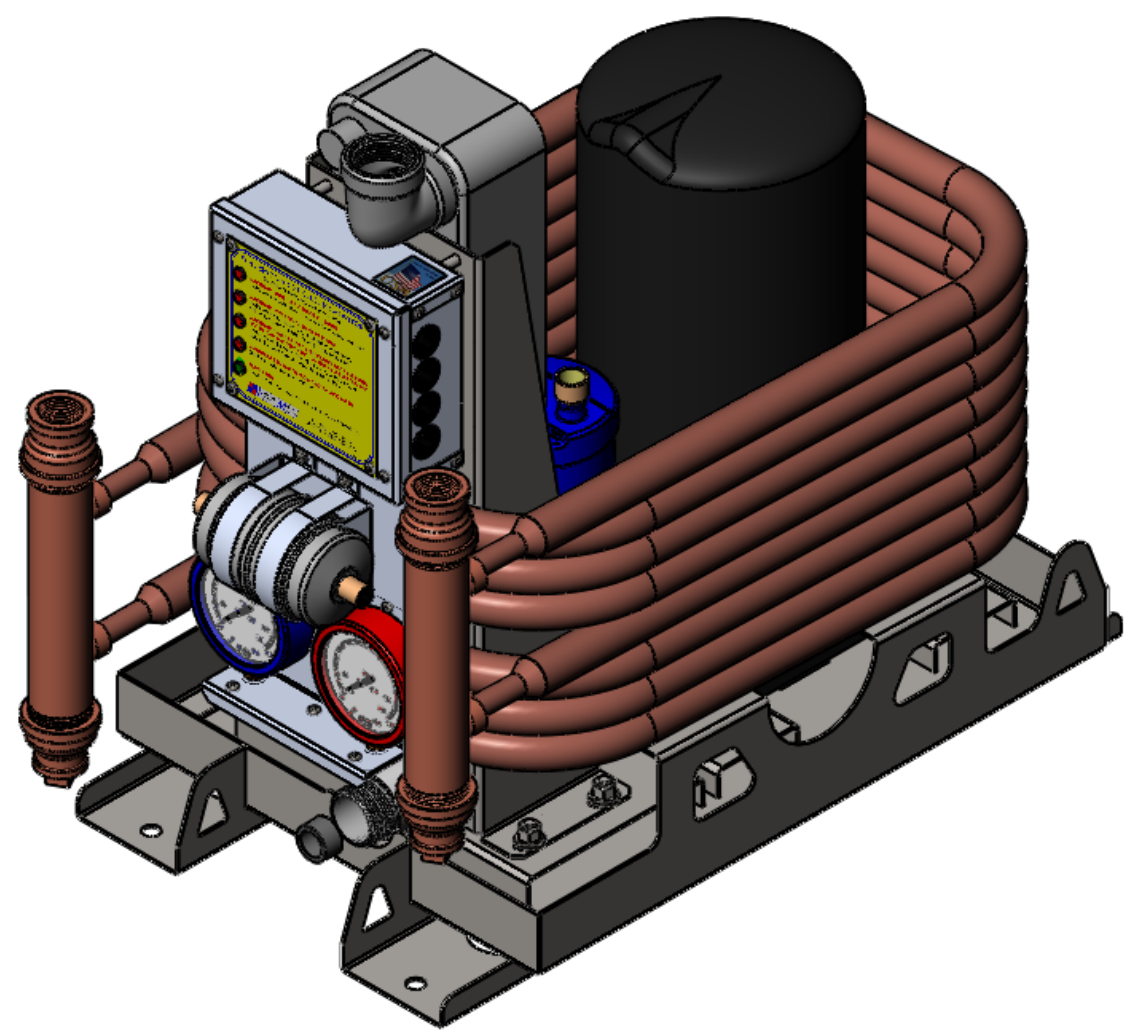

31	ZR42K5-PFV-800	COMPRESSOR, 1PH, 60 Hz, 208-230V	1
30	V6-414080-170	REVERSING VALVE LESS COIL, V6-414080-170, RANCO	1
29	HPC-104-S	FILTER DRIER, REVERSIBLE, LIQUID LINE, TYPE HPC-104-S, CATCH-ALL	1
28	FM60205	EVAPORATOR, CHILLED WATER, FM48CW & FM60CW	1
27	8NWLOS	8-32 LOCK WASHER SS	4
26	8CNMES	8-32 MACHINE SCREW NUT SS	4
25	80280-001	WELDMENT, MANIFOLD, 1 1/4" PIPE X 9.25"L, FM18CW - FM60CW	2
24	80264-001	WELDMENT, BASE, CHILLER, FM60CW	1
23	72396	#8-32 x 3/8" PHMS 18-8 SS	10
22	70658-001	FABRICATION, SADDLE, FILTER DRIER, CHILLER, FM60CW	1
21	70657-002	FABRICATION, STRAP, FILTER DRIER, CHILLER, FM360CW	2
20	70656-001	FABRICATION, BRACKET, LIQUID GAUGE & FILTER DRYER, CHILLER, FM60CW	1
19	70655-001	FABRICATION, PANEL, LIQUID GAUGE & FILTER DRIER, CHILLER, FM60CW	1
18	70654-001	FABRICATION, BRACKET, EVAPORATOR, CHILLER, FM60CW	1
17	60071-001	STANDOFF, .385 ID X 1.406 OD X 1.00 THK, 70 DURO EPDM BLACK	4
16	60070-001	WASHER, .385 ID X 1.406 OD X .25 THK, 60 DURO EPDM BLACK	4
15	60052-001	SUCTION ACCUMULATOR, CHILLED WATER, FM48CW & FM60CW	1
14	60045-002	PRESSURE GAUGE, LOW SIDE, BLUE, YELLOW JACKET 49002	1
13	60045-001	PRESSURE GAUGE, HIGH SIDE, RED, YELLOW JACKET49001	1
12	50016-001	FABRICATION, TUBING, CHILLER, FM60CW	2
11	4830K241	1 1/4" NPT FULLY THREADED NIPPLE, 304 SS	1
10	4464K66	1 1/4" NPT COUPLING, 304 SS	1
9	4464K17	1 1/4" NPT 90 DEG ELBOW, 304 SS	1
8	4429K761	REDUCING COUPLING, 1 1/2" NPT - 3/4" NPT, CAST BRASS	2
7	4429K743	REDUCING COUPLING, 1 1/4" NPT - 1" NPT, CAST BRASS	2
6	4429K315	PLUG, 3/4" NPT, CAST BRASS	2
5	37NWLOS	3/8 LOCK WASHER SS	12
4	37N125WFES	3/8 X 1-1/4 FENDER WASHER SS	4
3	37N125WFES	3/8 X 1-1/4 FENDER WASHER SS	4
2	37CNFHS	3/8 HEX FINISH NUT SS	12
1	20014-001	ASSEMBLY, ENCLOSURE, LOW VOLTAGE, CHILLERS	1
<b>ITEM NO.</b>	<b>PART NUMBER</b>	<b>DESCRIPTION</b>	20063-001/QTY.

**Flagship Marine**  
Components  
Factory Direct  
Price

**FLAGSHIP MARINE, INC.**  
2427 SE DIXIE HIGHWAY  
STUART | FLORIDA | 34996 | USA  
(772) 283-1609 | (800) 316-6426  
FAX (772) 283-4611

**PROPRIETARY AND CONFIDENTIAL**  
THIS DOCUMENT CONTAINS INFORMATION  
PROPRIETARY TO **FLAGSHIP  
MARINE, INC.** NO PART MAY BE  
REPRODUCED, USED IN ANY FORM,  
OR STORED ELECTRONICALLY  
WITHOUT THE WRITTEN PERMISSION OF  
**FLAGSHIP MARINE, INC.**

UNLESS OTHERWISE SPECIFIED:		NAME	DATE
DIMENSIONS ARE IN INCHES		DRAWN	SWC 2/4/2011
TOLERANCES:		CHECKED	TCM -
FRACTIONS ± 1/32		ENG APPR.	TCM -
ANG: MACH ± 0°30' BEND ± 2°		MFG APPR.	TCM -
DECIMALS .XX ± .01		Q.A.	EAS -
.XXX ± .005			
HOLE Ø .XX ± .005			
INTERPRET GEOMETRIC TOLERANCING PER: ASME Y14.5M			
MATERIAL		PERP STRAIGHTNESS	∓ .003/IN
		FLATNESS	∓ .005/IN
		THREADS:	
		EXTERNAL - CLASS 2A	
		INTERNAL - CLASS 2B	
FINISH		MACHINED SURFACES:	√ U.O.S
NEXT ASSY	USED ON		
APPLICATION	DO NOT SCALE DRAWING		

**TITLE:** ASSEMBLY, CHILLER, FM48CW, 25L X 15.50W X 23H

**PART NO.** 20063-001

**SIZE** B **DWG. NO.** FM20063 **REV** 01

**OLD PART NO.** -

**SCALE:** 1:5 **WGT:** 282.04 LBS **SHEET** 1 OF 2

2. PREFERRED LIMITS AND FITS PER ANSI B4.1 (INCHES).  
1. DIMENSIONING & TOLERANCING PER ASME Y14.5M.  
NOTES:

8 7 6 5 4 3 2 1

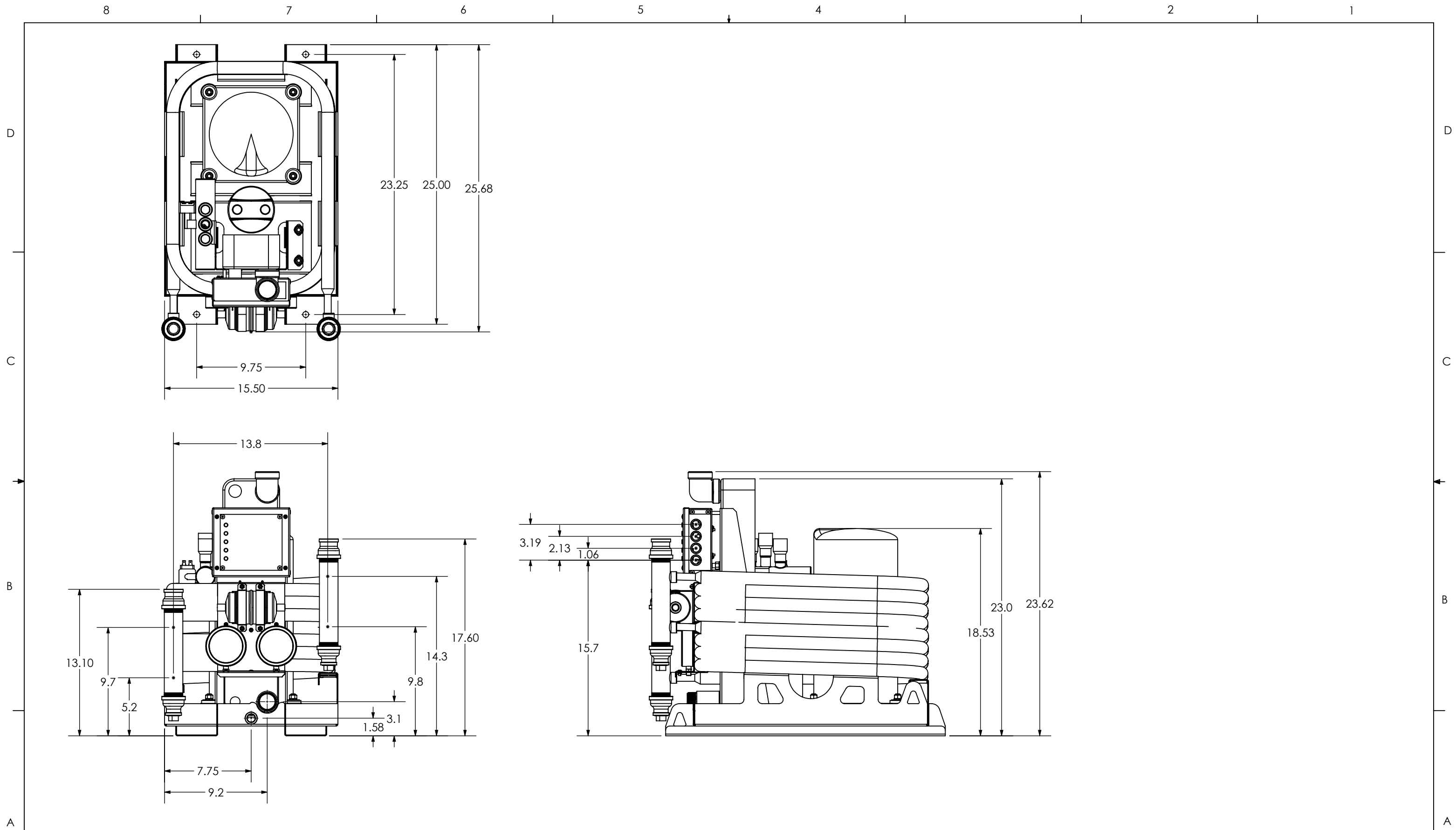

**Flagship Marine**  
 Commercial Quality Factory Direct Prices  
 2427 SE DIXIE HIGHWAY | STUART | FLORIDA | 34996 | USA  
 (772) 283-1609 | (800) 316-6426 FAX (772) 283-4611

DRAWN -  
 CHECKED -  
 ENG APPR. -

SIZE B  
 WGT: 282.04 LBS

DRAWING NO. **FM20063**  
 SCALE: 1:8

REV **01**  
 SHEET 2 OF 2