

PART NUMBER	DESCRIPTION	FLAGSHIP MARINE, INC.				
		REV.	ZONE	DESCRIPTION	DATE	ENG APPROVAL
20201-001	ASSEMBLY, AIR COOLED, CHILLER, FM120CWAC-V, 240V	01	-	INITIAL CHECK-IN	6/27/2012	-

D
C
B
A

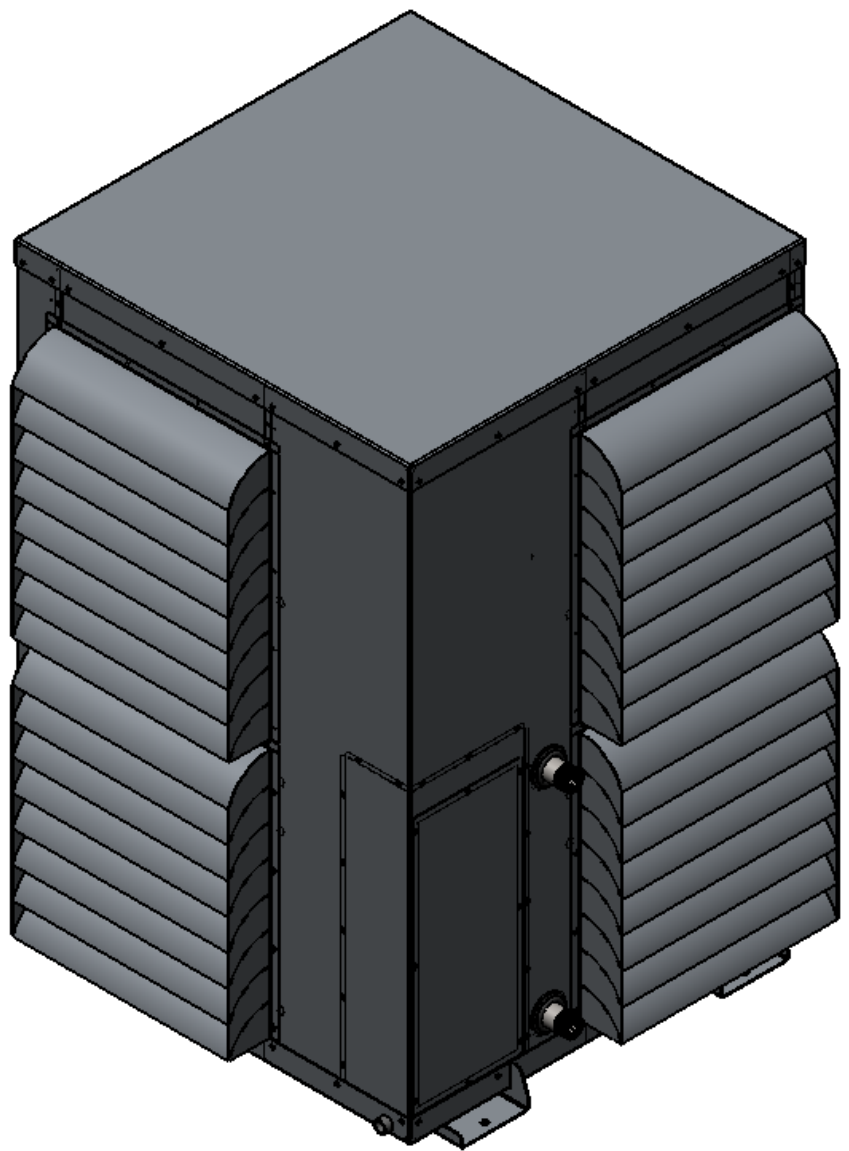

37	70792-001	FABRICATION, CAP, BIVECTOR, AIR COOLED, CHILLER, FM120-V/180CWAC	1
36	70791-001	FABRICATION, CAP, CORNER, ELECTRICAL CLOSEOUT, AIR COOLED, CHILLER, FM120-V/180CWAC	1
35	70786-002	FABRICATION, PANEL, BIVECTOR, AIR COOLED, CHILLER, FM120-V/180CWAC	1
34	60206-001	EVAPORATOR, CHILLED WATER, FM96CW & FM120CW	1
33	60272-001	COMPRESSOR, SCROLL, 1PH, 60 Hz, 208V	1
32	60304-001	MOTOR, 2HP, 1730RPM, 1PH, 60HZ, 56HZ, 3528LC, TEFC, F1, 7/8" SHAFT	2
31	70785-012	FABRICATION, PANEL, CORNER, INTAKE, AIR COOLED, CHILLER, FM120CWAC-V	1
30	70785-011	FABRICATION, PANEL, CORNER, INTAKE, AIR COOLED, CHILLER, FM120CWAC-V	1
29	70788-002	FABRICATION, PANEL, CLOSEOUT, AIR COOLED, CHILLER, FM120CWAC-V	3
28	80160-002	WELDMENT, SHROUD PANEL, FAN, AIR COOLED, CHILLER, FM120CWAC-V	1
27	70784-012	FABRICATION, PANEL, CORNER, EXHAUST, AIR COOLED, CHILLER, FM120CWAC-V	1
26	70784-011	FABRICATION, PANEL, CORNER, EXHAUST, AIR COOLED, CHILLER, FM120CWAC-V	1
25	80189-002	WELDMENT, BASE, AIR COOLED, CHILLER, FM120CWAC-V/FM180CWAC	1
24	V6-414080-170	REVERSING VALVE LESS COIL, V6-414080-170, RANCO	1
23	HPC-104-S	FILTER DRIER, REVERSIBLE, LIQUID LINE, TYPE HPC-104-S, CATCH-ALL	1
22	8C375MXP	#8-32 x 3/8" PHMS 18-8 SS	12
21	60156-001	GRILL, 3/8" WIRE SPACE, 4" CNTR PLATE, 11ga (.120) SPIRAL, (8).187 SPOKES 304SS, MT HOLES #8	2
20	80065-001	WELDMENT, PANEL, LOUVER, SELF CONTAINED, AIR COOLED, UNIVERSAL	6
19	4830K129		2
18	20016-011	ASSEMBLY, CONTROL BOX, SELF CONTAINED, A/C, SINGLE PHASE, WITH OPTIONAL HEAT, 48K-120K UNIVERSAL	1
17	60073-001	FAN, 3572CFM, 0.65inH2O, 0.66HP, 22/5-10/P3HR/30/PA/0.875/0.187/BR/JA	2
16	70787-001	FABRICATION, PANEL, ACCESS, AIR COOLED, CHILLER, FM60/120-V/180CWAC	1
15	70627-002	FABRICATION, BRACKET, EVAPORATOR, SELF CONTAINED, AIR COOLED, CHILLER UNIT, FM60CWAC	1
14	6359K37	GROMMET, SNAP-IN SEALING, 1.25" PIPE, FITS 1.62" TO 1.75" PIPE DIA.	2
13	60533-001	RIVET, 3/16" DIA. .062-.125" GRIP RANGE, SSB6-2S	69
12	70781-001	FABRICATION, LID, AIR COOLED, CHILLER, FM60/120-V/180CWAC	1
11	60131-001	GROMMET, 11/16" PUSH-IN LOCKING, NYLON	8
10	70789-001	FABRICATION, PANEL, CORNER, ELECTRICAL CLOSEOUT, AIR COOLED, CHILLER, FM60/120-V/180CWAC	1
9	60071-001	STANDOFF, .385 ID X 1.406 OD X 1.00 THK, 70 DURO EPDM BLACK	4
8	60070-001	WASHER, .385 ID X 1.406 OD X .25 THK, 60 DURO EPDM BLACK	4
7	60216-001	EVAPORATOR, 36000 MBTU, 17.50HX18.13W, 4 ROW	6
6	4464K66	1 1/4" NPT COUPLING, 304 SS	2
5	37NWLOS	3/8 LOCK WASHER SS	8
4	37N125WFES	3/8 X 1-1/4 FENDER WASHER SS	8
3	37CNFHS	3/8 HEX FINISH NUT SS	8
2	20014-001	ASSEMBLY, ENCLOSURE, LOW VOLTAGE, CHILLERS	1
1	1131943	#8-18 X 1/2" HWH #3 PT SELF DRILLING SCREW, 410 SS	142

ITEM NO.	PART NUMBER	DESCRIPTION	20201-001/QTY.
----------	-------------	-------------	----------------

FLAGSHIP MARINE, INC. BILL OF MATERIALS

<p>FLAGSHIP MARINE, INC. 2427 SE DIXIE HIGHWAY STUART FLORIDA 34996 USA (772) 283-1609 (800) 316-6426 FAX (772) 283-4611</p> <p>PROPRIETARY AND CONFIDENTIAL</p> <p>THIS DOCUMENT CONTAINS INFORMATION PROPRIETARY TO FLAGSHIP MARINE, INC. NO PART MAY BE REPRODUCED, USED IN ANY FORM, OR STORED ELECTRONICALLY WITHOUT THE WRITTEN PERMISSION OF FLAGSHIP MARINE, INC.</p>			UNLESS OTHERWISE SPECIFIED: DIMENSIONS ARE IN INCHES TOLERANCES: FRACTIONS ± 1/32 ANG: MACH ± 0°30' BEND ± 2° DECIMALS .XX ± .01 .XXX ± .005 HOLE Ø .XX ± .005		NAME	DATE	TITLE: ASSEMBLY, AIR COOLED, CHILLER, FM120CWAC-V, 240V PART NO. 20201-001
				DRAWN	SWC	10/16/2009	
				CHECKED	TCM	-	
				ENG APPR.	TCM	-	
					MFG APPR.	TCM	-
					Q.A.	EAS	-
			INTERPRET GEOMETRIC TOLERANCING PER: ASME Y14.5M				
			MATERIAL	PERP STRAIGHTNESS	∓	.003/IN	SIZE B DWG. NO. FM20201 REV 01
				FLATNESS	∓	.005/IN	
			FINISH	THREADS:			OLD PART NO. - SCALE: 1:16 WGT: 1448.84 LB\$ SHEET 1 OF 2
				EXTERNAL - CLASS 2A INTERNAL - CLASS 2B MACHINED SURFACES: √ U.O.S			
	NEXT ASSY	USED ON					
	APPLICATION		DO NOT SCALE DRAWING				

2. PREFERRED LIMITS AND FITS PER ANSI B4.1 (INCHES).
1. DIMENSIONING & TOLERANCING PER ASME Y14.5M.
NOTES:

8 7 6 5 4 3 2 1

8 7 6 5 4 2 1

D

C

B

A

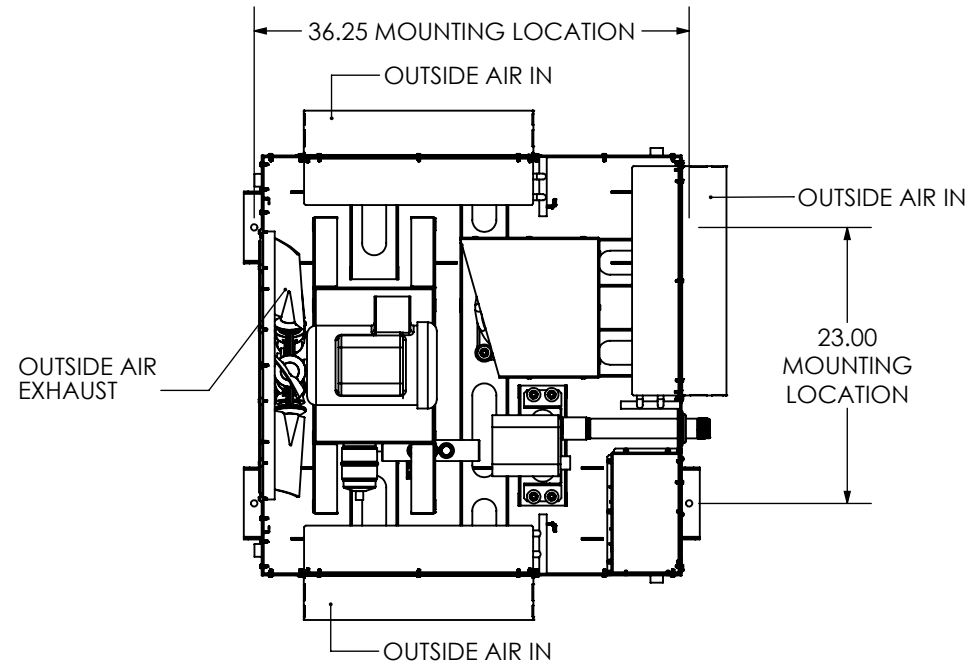

TOP VIEW
WITH LID REMOVED FOR CLAIRITY

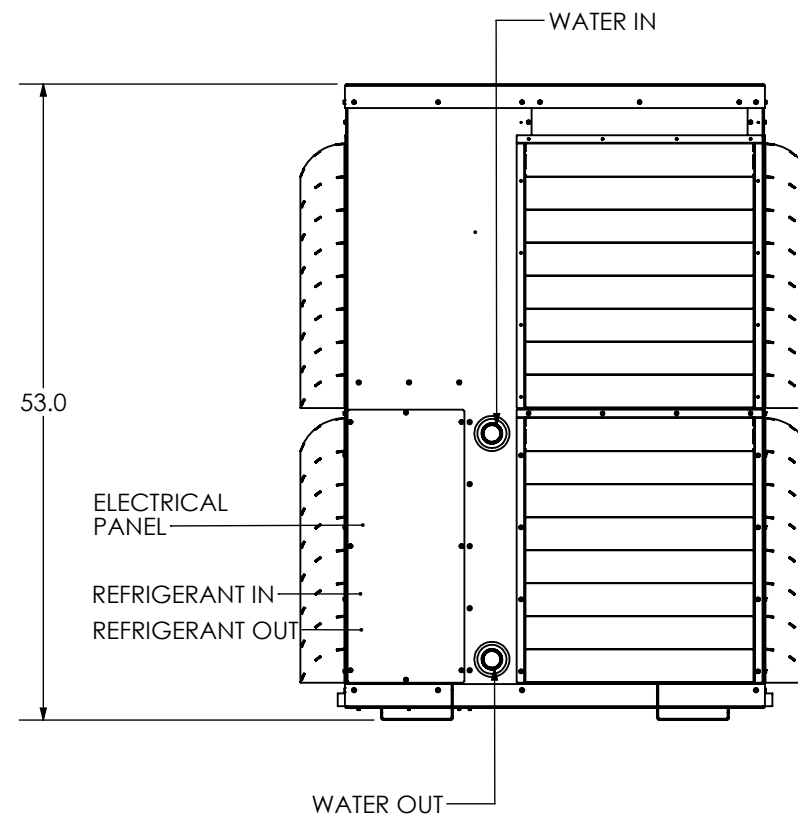
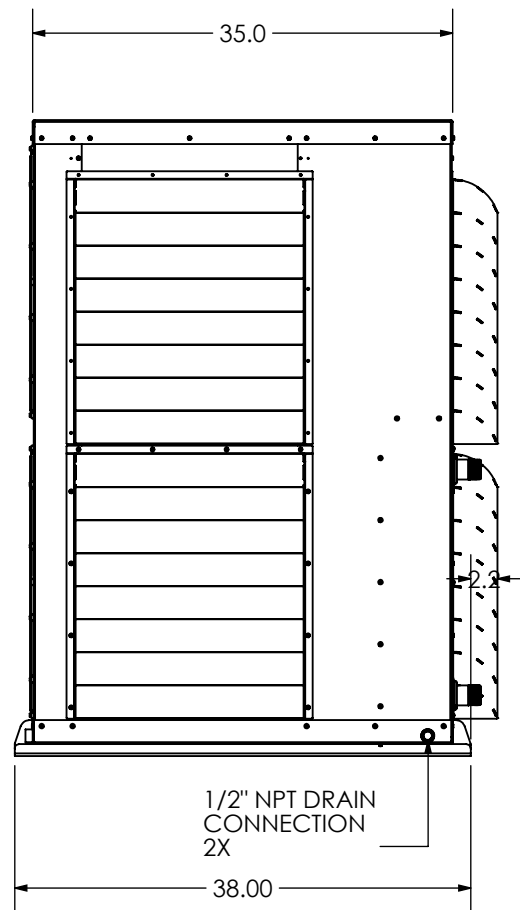
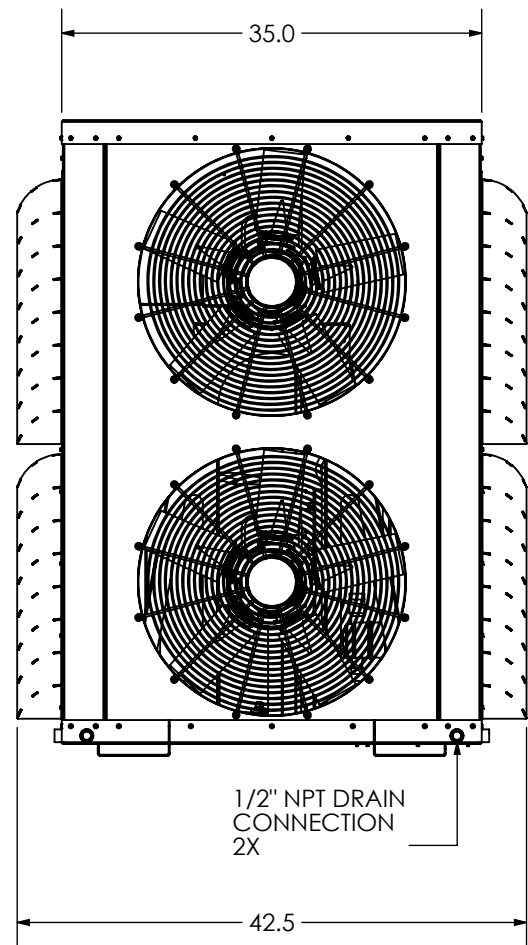

 <p>Commercial Quality Factory Direct Prices</p> <p>2427 SE DIXIE HIGHWAY STUART FLORIDA 34996 USA (772) 283-1609 (800) 316-6426 FAX (772) 283-4611</p>	DRAWN -	SIZE B	DRAWING NO. FM20201	REV 01
	CHECKED -	WGT: 1448.84 LBS		SCALE: 1:16
	ENG APPR. -	SHEET 2 OF 2		

8 7 6 5 4 3 2 1