

PART NUMBER	DESCRIPTION
20024-001	ASSEMBLY, AIR CONDITIONER FM18R, 120V SIDE
20024-011	ASSEMBLY, AIR CONDITIONER FM18R, 120V SIDE, WITH OPTIONAL HEAT
20024-101	ASSEMBLY, AIR CONDITIONER FM18R, 230V SIDE
20024-111	ASSEMBLY, AIR CONDITIONER FM18R, 230V SIDE, WITH OPTIONAL HEAT

FLAGSHIP MARINE, INC.				
REV.	ZONE	DESCRIPTION	DATE	ENG APPROVAL
D		MULTIPLE UPDATED INCLUDING TO COMPRESSOR AND EVAPORATOR	10/12/2017	
E		ADDED LOCATIONAL TAB FOR SHROUD AND WATER IN/OUT TAGS	7/17/2018	
F		REMOVED 60657-001	11/16/2018	

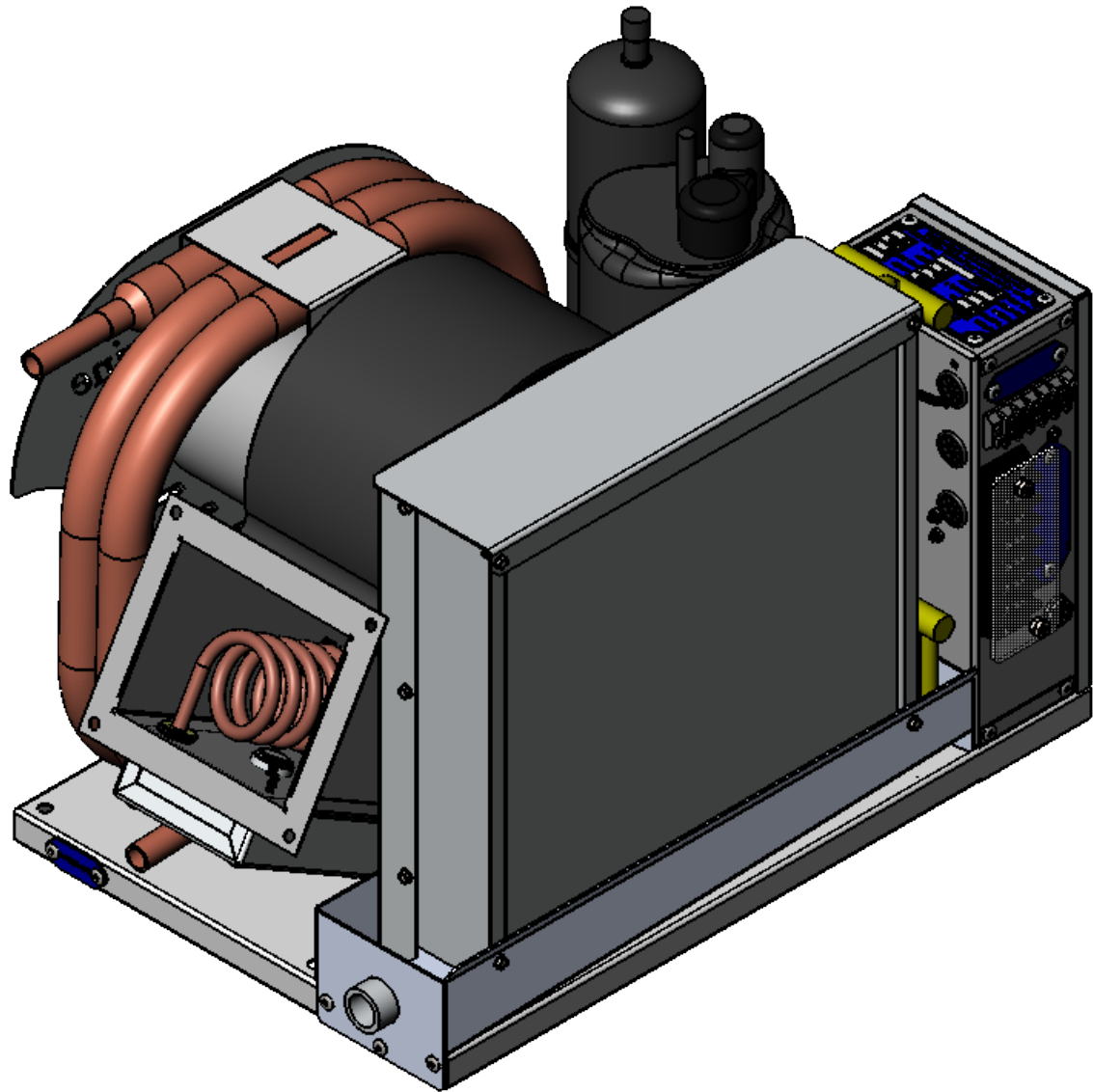

20024-011 SHOWN
SEE SHEET 3 OF 4 FOR DIMENSIONS

41	1	1	1	1	80901-001	WELDMENT, DRY DRAIN PAN, EVAPORATOR, AIR CONDITIONER, FM12, FM16 & FM18R, SIDE
40	1	1	1	1	80025-001	WELDMENT, BASE, AIR CONDITIONER, FM16R & FM18R
39	1	1	1	1	70999-001	TAG, WATER IN, ANODIZED, ETCHED
38	1	1	1	1	70998-001	TAG, WATER OUT, ANODIZED, ETCHED
37	1	1	1	1	70904-001	FABRICATION, SHROUD, EVAPORATOR, AIR CONDITIONER, FM16R & FM18R, SIDE
36	1	1	1	1	70105-002	FABRICATION, BRACKET, CONDENSER, AIR CONDITIONER, FM16R & FM18R, SIDE
35	1	1	1	1	70099-001	FABRICATION, SUPPORT, BASE, AIR CONDITIONER, FM16R & FM18R
34	1	1	1	1	70098-001	FABRICATION, BRACKET, BLOWER, AIR CONDITIONER, FM12R, FM16R & FM18R
33	1	1	1	1	70091-001	DETAIL, PLATE, DECORATIVE CONDENSER COVER, FM12R /FM16R / FM18R
32	-	1	-	1	70086-001	FABRICATION, LID, ENCLOSURE, HEATER COIL, AIR CONDITIONER, FM9R - FM20R
31	-	1	-	1	70085-001	FABRICATION, ENCLOSURE, HEATER COIL, AIR CONDITIONER, FM9R - FM20R
30	A/R	A/R	A/R	A/R	61000-001	INSULATION, 1/8" FOAM PEEL AND STICK
29	A/R	A/R	A/R	A/R	60998-001	TAPE, CORK ROLL, 30"x2"
28	1	1	-	-	60788-001	COMPRESSOR, 16/18K UNITS, GKS134CAA, 13300 BTU, 115v, R410a, 50/370 RUN CAP, OVERLOAD MRA4720-12027
27	-	-	1	1	60773-001	COMPRESSOR, 16/18K UNITS, GK141KAB, 13500 BTU, 230v, R410a, 35/370 RUN CAP, OVERLOAD MRA12105-12026
26	4	4	4	4	60656-001	BOLT, M6 X 1.0 X 12, HEX HEAD, SS
25	3	3	3	3	60539-001	NUT, 3/8-16 NYLON LOCK NUT 18-8 SS
24	3	3	3	3	60534-001	WASHER, 3/8 X 1 1/4 FENDER WASHER, 18-8 SS
23	25	25	25	25	60533-001	RIVET, 3/16" DIA. .062-.125" GRIP RANGE, SSB6-2S
22	16	20	16	20	60527-001	SELF TAP, #8 X 1/2 HWH SELF DRILL 18-8 SS
21	-	4	-	4	60517-001	SCREW, #8-32 X 3/8" PAN HEAD MACHINE SCREW, #2 DRIVE PHILLIPS, 18-8 SS
20	A/R	A/R	A/R	A/R	60329-002	REFRIGERANT, R410a
19	1	1	1	1	60212-001	EVAPORATOR, 18000 MBTU, 12HX12W, 3 ROW
18	1	1	1	1	60148-001	SWITCH, HIGH PRESSURE, SPST, OPEN ON PRESSURE RISE, OPEN (600 PSI) CLOSE (475 PSI)
17	-	1	-	1	60131-001	GROMMET, 11/16" PUSH-IN LOCKING, NYLON
16	1	1	1	1	60079-002	DRIER, FILTER, 5/16" SOLDER, 2 TON, SUD112
15	15	15	15	15	60070-001	WASHER, .385 ID X 1.406 OD X .25 THK, 60 DURO EPDM BLACK
14	-	1	-	1	60062-001	SWITCH, THERMAL LIMIT, 130 DEG. F, NC
13	-	-	-	1	60032-002	HEATER ELEMENT, COIL, 45"L, 8MM, 2000W, 240VAC, DBL END THRD BULKHEAD
12	-	1	-	-	60032-001	HEATER ELEMENT, COIL, 45"L, 8MM, 2000W, 120VAC, DBL END THRD BULKHEAD
11	-	-	1	1	60010-001	BLOWER, PSC, SHADED POLE, 1TDT3, 230V
10	1	1	-	-	60006-001	BLOWER, PSC, SHADED POLE, 1TDT2, 115V
9	3	3	3	3	40102-001	VALVE, 1/4" STANDARD SERVICE, CAP W/RUBBER O-RING
8	1	1	1	1	40096-001	VALVE, EXPANSION, BALANCED PORT, 2-5 1/2-TON, R22, SBQBODY3X4
7	1	1	1	1	40086-001	VALVE, EXPANSION, HEAD, UP TO 5 TON, R410A, KT45ZGA
6	1	1	1	1	40078-001	ORIFICE, CARTRIDGE, BALANCED PORT VALVES, BLUE, 3/4-1-1/2 TON (R22), 1-1.75 TON (R410a), BQC-A
5	A/R	A/R	A/R	A/R	30230-001	LOOM, SPLIT-TYPE, BLUE TRACER, 1/2", 1100', M125-0120-A
4	1	1	1	1	30023-001	WIRING, SELF-CONTAINED, REVERSE CYCLE, COOL ONLY, ELECTRIC HEAT, 115/230/1/50/60
3	1	1	1	1	20515-001	THERMOSTAT, BLUE MOUNTING PLATE, (4) WIRE, 20'
2	1	1	1	1	20157-001	CONDENSER, LIQUID COOLED, FM12R, FM16R, FM18R
1	1	1	1	1	20145-001	ASSEMBLY, CONTROL ENCLOSURE, SELF-CONTAINED 9K-36K, INSTALLED ON-BOARD, 115v/230v

ITEM NO.	QTY	001 QTY	101 QTY	111 QTY	PART NUMBER	DESCRIPTION
FLAGSHIP MARINE, INC. BILL OF MATERIALS						
UNLESS OTHERWISE SPECIFIED:						
DIMENSIONS ARE IN INCHES						
TOLERANCES:						
FRACTIONS ± 1/32						
ANG: MACH ± 0°30' BEND ± 2°						
DECIMALS .XX ± .01						
.XXX ± .005						
HOLE Ø .XX ± .005						
INTERPRET GEOMETRIC TOLERANCING PER: ASME Y14.5M						
MATERIAL						
FINISH						
NONE						
NEXT ASSY						
USED ON						
APPLICATION						
DO NOT SCALE DRAWING						
PERP ± .003/IN						
STRAIGHTNESS ± .005/IN						
FLATNESS ± .005/IN						
THREADS:						
EXTERNAL - CLASS 2A						
INTERNAL - CLASS 2B						
MACHINED SURFACES: ✓ U.O.S						
TITLE: ASSEMBLY, AIR CONDITIONER FM18R, SIDE						
PART NO. 20024-XX1						
SIZE	DWG. NO.		REV			
B	FM20024		F			
OLD PART NO. -						
SCALE: 1:4		WGT: 139.10 LBS		SHEET 1 OF 5		

Flagship Marine
FLAGSHIP MARINE, INC.
 2427 SE DIXIE HIGHWAY
 STUART | FLORIDA | 34996 | USA
 (772) 283-1609 | (800) 316-6426
 FAX (772) 283-4611

PROPRIETARY AND CONFIDENTIAL
 THIS DOCUMENT CONTAINS INFORMATION PROPRIETARY TO FLAGSHIP MARINE, INC. NO PART MAY BE REPRODUCED, USED IN ANY FORM, OR STORED ELECTRONICALLY WITHOUT THE WRITTEN PERMISSION OF FLAGSHIP MARINE, INC.

- 3. NO SHARP EDGES PERMITTED.
- 2. PREFERRED LIMITS AND FITS PER ANSI B4.1 (INCHES).
- 1. DIMENSIONING & TOLERANCING PER ASME Y14.5M.

NOTES:

PART NUMBER	DESCRIPTION
20024-002	ASSEMBLY, AIR CONDITIONER FM18R, 120V TOP
20024-012	ASSEMBLY, AIR CONDITIONER FM18R, 120V TOP, WITH OPTIONAL HEAT
20024-102	ASSEMBLY, AIR CONDITIONER FM18R, 230V TOP
20024-112	ASSEMBLY, AIR CONDITIONER FM18R, 230V TOP, WITH OPTIONAL HEAT

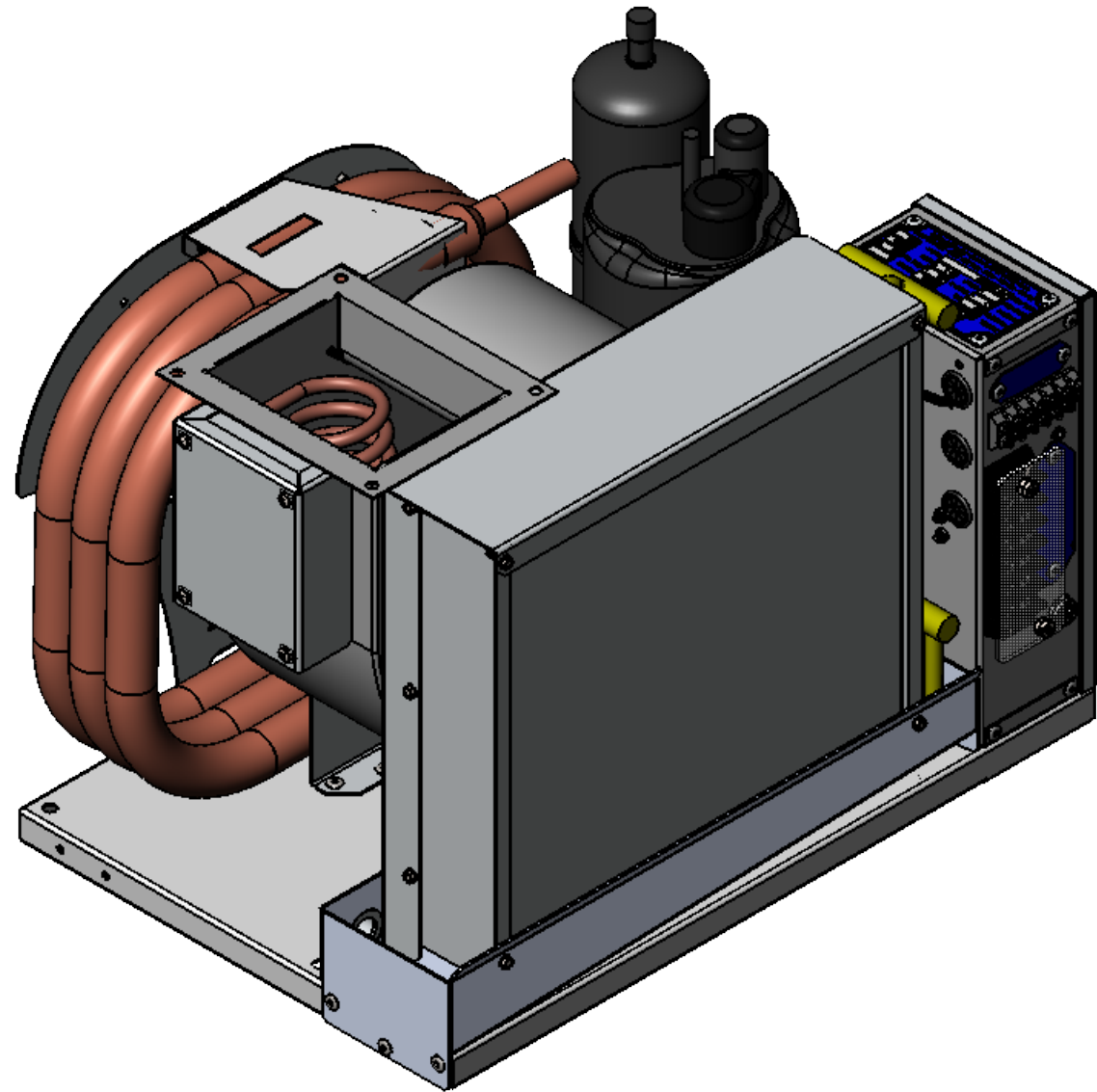

20024-012 SHOWN
SEE SHEET 4 OF 4 FOR DIMENSIONS

41	1	1	1	1	80901-002	WELDMENT, DRY DRAIN PAN, EVAPORATOR, AIR CONDITIONER, FM12, FM16 & FM18R, TOP
40	1	1	1	1	80025-001	WELDMENT, BASE, AIR CONDITIONER, FM16R & FM18R
39	1	1	1	1	70999-001	TAG, WATER IN, ANODIZED, ETCHED
38	1	1	1	1	70998-001	TAG, WATER OUT, ANODIZED, ETCHED
37	1	1	1	1	70904-002	FABRICATION, SHROUD, EVAPORATOR, AIR CONDITIONER, FM16R & FM18R, TOP
36	1	1	1	1	70106-002	FABRICATION, BRACKET, CONDENSER, AIR CONDITIONER, FM16R & FM18R, TOP
35	1	1	1	1	70099-001	FABRICATION, SUPPORT, BASE, AIR CONDITIONER, FM16R & FM18R
34	1	1	1	1	70098-001	FABRICATION, BRACKET, BLOWER, AIR CONDITIONER, FM12R, FM16R & FM18R
33	1	1	1	1	70091-001	DETAIL, PLATE, DECORATIVE CONDENSER COVER, FM12R /FM16R / FM18R
32	-	1	-	1	70086-001	FABRICATION, LID, ENCLOSURE, HEATER COIL, AIR CONDITIONER, FM9R - FM20R
31	-	1	-	1	70085-001	FABRICATION, ENCLOSURE, HEATER COIL, AIR CONDITIONER, FM9R - FM20R
30	A/R	A/R	A/R	A/R	61000-001	INSULATION, 1/8" FOAM PEEL AND STICK
29	A/R	A/R	A/R	A/R	60998-001	TAPE, CORK ROLL, 30"x2"
28	1	1	-	-	60788-001	COMPRESSOR, 16/18K UNITS, GKS134CAA, 13300 BTU, 115v, R410a, 50/370 RUN CAP, OVERLOAD MRA4720-12027
27	-	-	1	1	60773-001	COMPRESSOR, 16/18K UNITS, GK141KAB, 13500 BTU, 230v, R410a, 35/370 RUN CAP, OVERLOAD MRA12105-12026
26	4	4	4	4	60656-001	BOLT, M6 X 1.0 X 12, HEX HEAD, SS
25	3	3	3	3	60539-001	NUT, 3/8-16 NYLON LOCK NUT 18-8 SS
24	3	3	3	3	60534-001	WASHER, 3/8 X 1 1/4 FENDER WASHER, 18-8 SS
23	25	25	25	25	60533-001	RIVET, 3/16" DIA. .062-.125" GRIP RANGE, SSB6-2S
22	16	20	16	20	60527-001	SELF TAP, #8 X 1/2 HWH SELF DRILL 18-8 SS
21	-	4	-	4	60517-001	SCREW, #8-32 X 3/8" PAN HEAD MACHINE SCREW, #2 DRIVE PHILLIPS, 18-8 SS
20	A/R	A/R	A/R	A/R	60329-002	REFRIGERANT, R410a
19	1	1	1	1	60212-001	EVAPORATOR, 18000 MBTU, 12HX12W, 3 ROW
18	1	1	1	1	60148-001	SWITCH, HIGH PRESSURE, SPST, OPEN ON PRESSURE RISE, OPEN (600 PSI) CLOSE (475 PSI)
17	-	1	-	1	60131-001	GROMMET, 11/16" PUSH-IN LOCKING, NYLON
16	1	1	1	1	60079-002	DRIER, FILTER, 5/16" SOLDER, 2 TON, SUD112
15	15	15	15	15	60070-001	WASHER, .385 ID X 1.406 OD X .25 THK, 60 DURO EPDM BLACK
14	-	1	-	1	60062-001	SWITCH, THERMAL LIMIT, 130 DEG. F, NC
13	-	-	-	1	60032-002	HEATER ELEMENT, COIL, 45"L, 8MM, 2000W, 240VAC, DBL END THRD BULKHEAD
12	-	1	-	-	60032-001	HEATER ELEMENT, COIL, 45"L, 8MM, 2000W, 120VAC, DBL END THRD BULKHEAD
11	-	-	1	1	60010-001	BLOWER, PSC, SHADED POLE, 1TDT3, 230V
10	1	1	-	-	60006-001	BLOWER, PSC, SHADED POLE, 1TDT2, 115V
9	3	3	3	3	40102-001	VALVE, 1/4" STANDARD SERVICE, CAP W/RUBBER O-RING
8	1	1	1	1	40096-001	VALVE, EXPANSION, BALANCED PORT, 2-5 1/2-TON, R22, SBQBODY3X4
7	1	1	1	1	40086-001	VALVE, EXPANSION, HEAD, UP TO 5 TON, R410A, KT45ZGA
6	1	1	1	1	40078-001	ORIFICE, CARTRIDGE, BALANCED PORT VALVES, BLUE, 3/4-1-1/2 TON (R22), 1-1.75 TON (R410a), BQC-A
5	A/R	A/R	A/R	A/R	30230-001	LOOM, SPLIT-TYPE, BLUE TRACER, 1/2", 1100', M125-0120-A
4	1	1	1	1	30023-001	WIRING, SELF-CONTAINED, REVERSE CYCLE, COOL ONLY, ELECTRIC HEAT, 115/230/1/50/60
3	1	1	1	1	20515-001	THERMOSTAT, BLUE MOUNTING PLATE, (4) WIRE, 20'
2	1	1	1	1	20157-001	CONDENSER, LIQUID COOLED, FM12R, FM16R, FM18R
1	1	1	1	1	20145-001	ASSEMBLY, CONTROL ENCLOSURE, SELF-CONTAINED 9K-36K, INSTALLED ON-BOARD, 115v/230v

ITEM NO.	QTY	DESCRIPTION	PART NUMBER
002	1	ASSEMBLY, AIR CONDITIONER FM18R, TOP	20024-XX2
012	1	ASSEMBLY, AIR CONDITIONER FM18R, 120V TOP, WITH OPTIONAL HEAT	
102	1	ASSEMBLY, AIR CONDITIONER FM18R, 230V TOP	
112	1	ASSEMBLY, AIR CONDITIONER FM18R, 230V TOP, WITH OPTIONAL HEAT	

FLAGSHIP MARINE, INC. BILL OF MATERIALS			
UNLESS OTHERWISE SPECIFIED:	NAME	DATE	TITLE:
DIMENSIONS ARE IN INCHES	SWC	8/2/2010	ASSEMBLY, AIR CONDITIONER FM18R, TOP
TOLERANCES:	TCM	-	
FRACTIONS ± 1/32	TCM	-	
ANG: MACH ± 0°30' BEND ± 2°	TCM	-	
DECIMALS .XX ± .01	TCM	-	
.XXX ± .005	TCM	-	
HOLE Ø .XX ± .005	TCM	-	
INTERPRET GEOMETRIC TOLERANCING PER: ASME Y14.5M	Q.A.	EAS	
MATERIAL	PERP	± .003/IN	SIZE
	STRAIGHTNESS	.005/IN	B
	FLATNESS	.005/IN	DWG. NO.
	THREADS:		FM20024
	EXTERNAL - CLASS 2A		REV
	INTERNAL - CLASS 2B		F
FINISH	MACHINED SURFACES: ✓ U.O.S		OLD PART NO. -
NONE			SCALE: 1:4
APPLICATION	DO NOT SCALE DRAWING		WGT: 138.57 LBS
			SHEET 2 OF 5

Flagship Marine
 FLAGSHIP MARINE, INC.
 2427 SE DIXIE HIGHWAY
 STUART | FLORIDA | 34996 | USA
 (772) 283-1609 | (800) 316-6426
 FAX (772) 283-4611

PROPRIETARY AND CONFIDENTIAL
 THIS DOCUMENT CONTAINS INFORMATION PROPRIETARY TO FLAGSHIP MARINE, INC. NO PART MAY BE REPRODUCED, USED IN ANY FORM, OR STORED ELECTRONICALLY WITHOUT THE WRITTEN PERMISSION OF FLAGSHIP MARINE, INC.

- NOTES:
3. NO SHARP EDGES PERMITTED.
 2. PREFERRED LIMITS AND FITS PER ANSI B4.1 (INCHES).
 1. DIMENSIONING & TOLERANCING PER ASME Y14.5M.

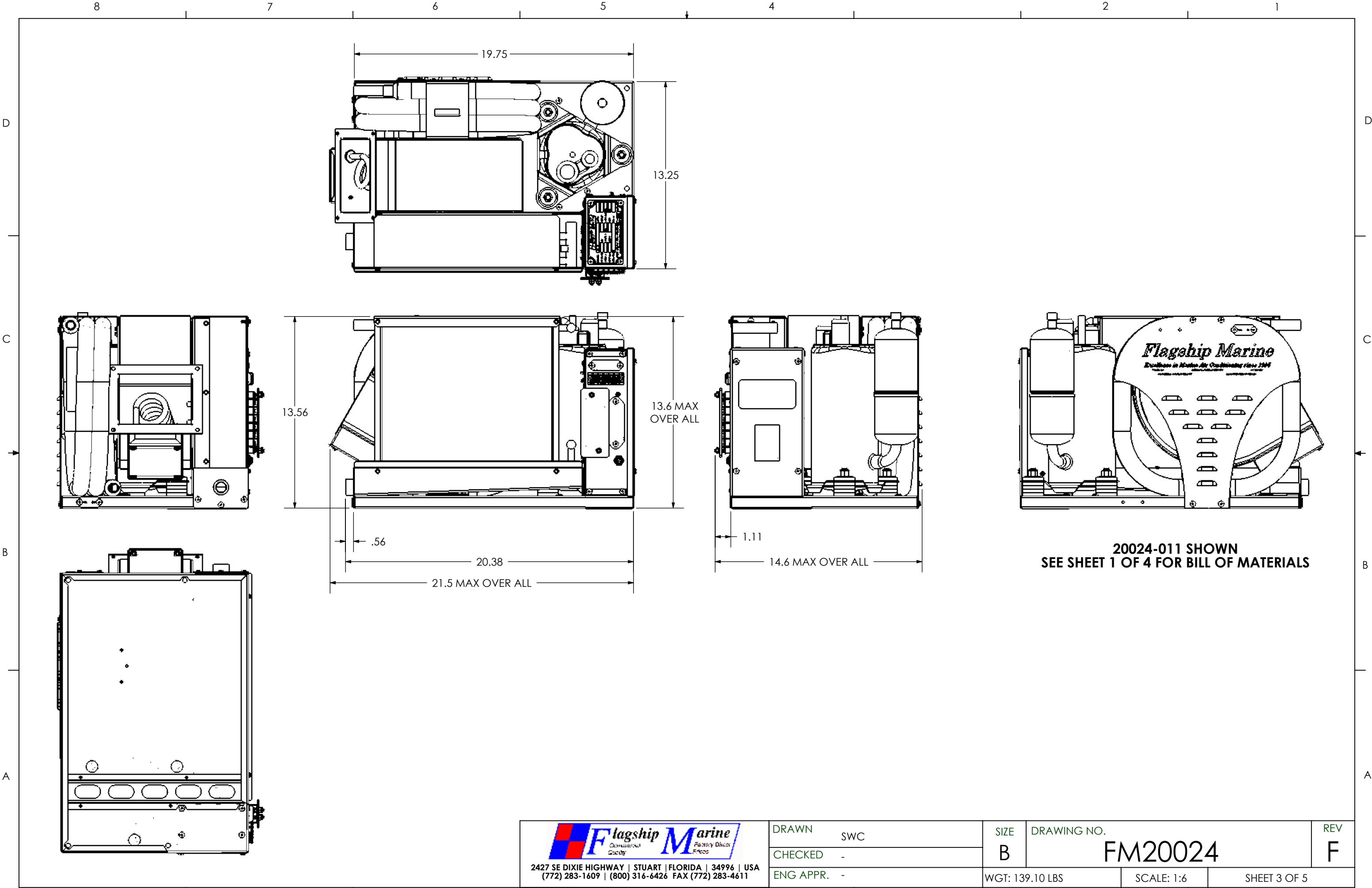

Flagship Marine
COMMERCIAL QUALITY Factory Direct Prices

2427 SE DIXIE HIGHWAY | STUART | FLORIDA | 34996 | USA
 (772) 283-1609 | (800) 316-6426 FAX (772) 283-4611

DRAWN	SWC	SIZE	DRAWING NO.	REV
CHECKED	-	B	FM20024	F
ENG APPR.	-	WGT: 139.10 LBS	SCALE: 1:6	SHEET 3 OF 5

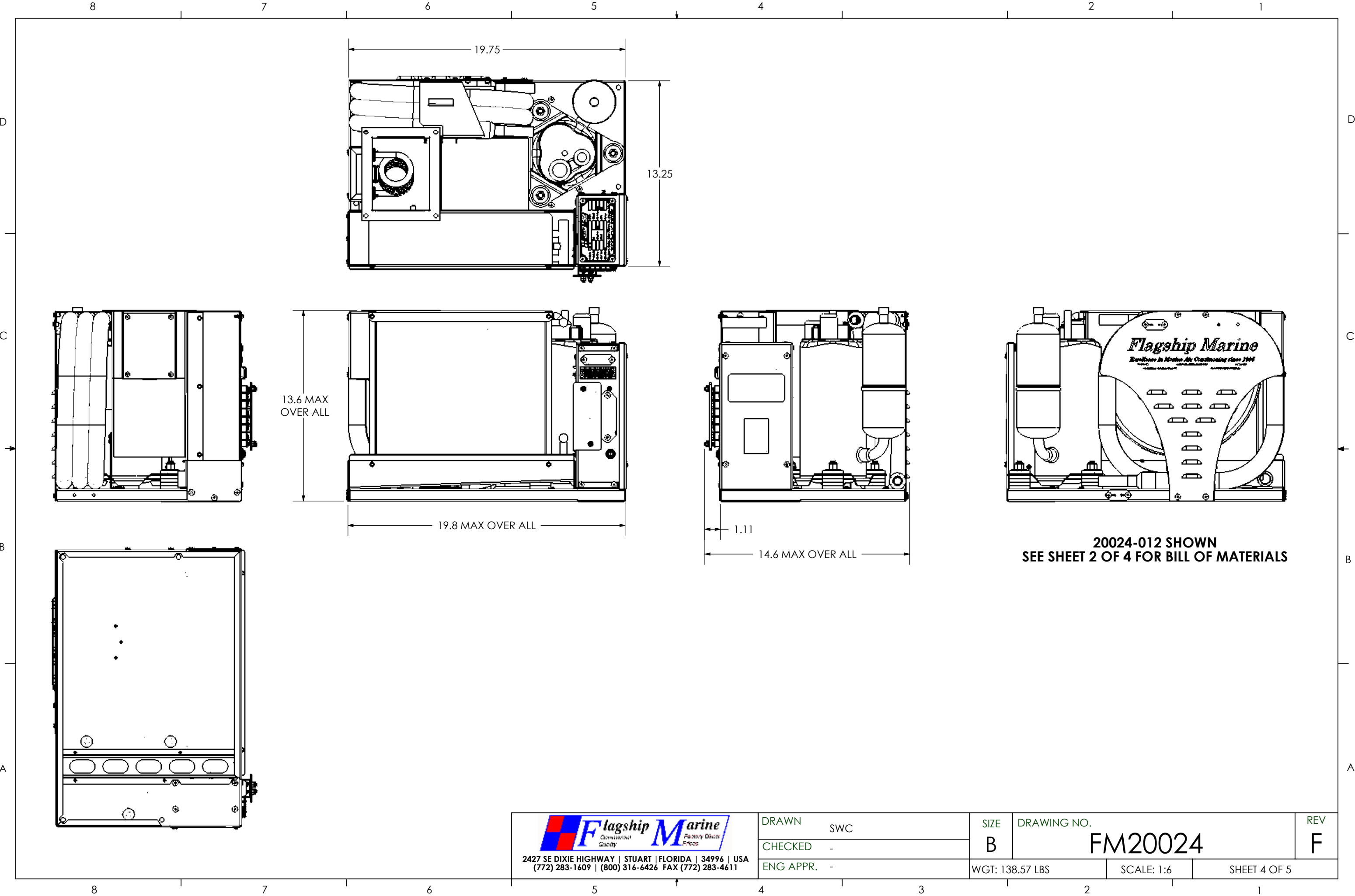

Flagship Marine
 Commercial Quality Factory Direct Prices

2427 SE DIXIE HIGHWAY | STUART | FLORIDA | 34996 | USA
 (772) 283-1609 | (800) 316-6426 FAX (772) 283-4611

DRAWN	SWC	SIZE	DRAWING NO.	REV
CHECKED	-	B	FM20024	F
ENG APPR.	-	WGT: 138.57 LBS	SCALE: 1:6	SHEET 4 OF 5

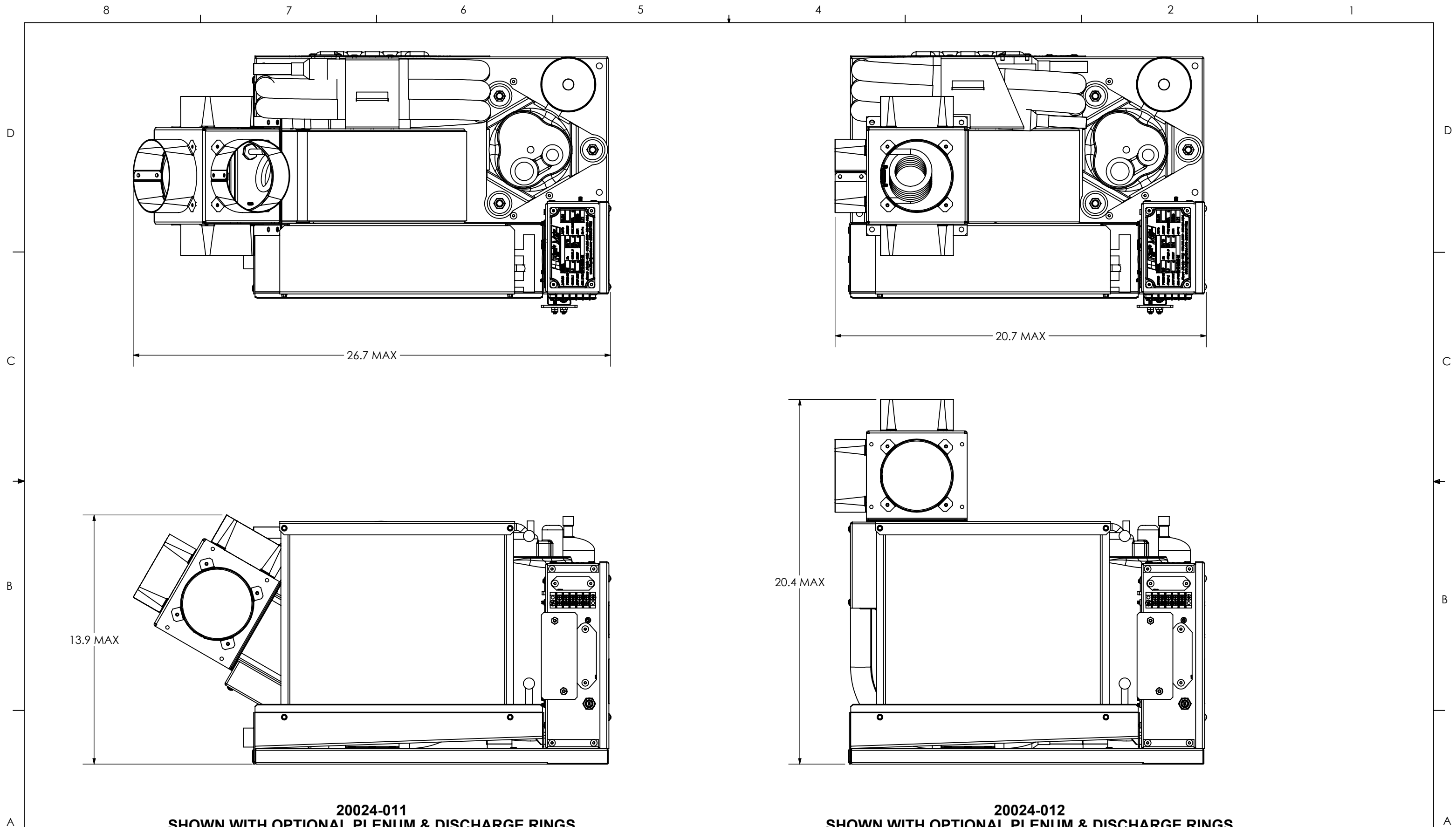

20024-011
SHOWN WITH OPTIONAL PLENUM & DISCHARGE RINGS
FOR DIMENTIONAL REFERENCE ONLY

20024-012
SHOWN WITH OPTIONAL PLENUM & DISCHARGE RINGS
FOR DIMENTIONAL REFERENCE ONLY

 2427 SE DIXIE HIGHWAY STUART FLORIDA 34996 USA (772) 283-1609 (800) 316-6426 FAX (772) 283-4611	DRAWN SWC	SIZE B	DRAWING NO. FM20024	REV F
	CHECKED -	WGT: 139.76 LBS	SCALE: 1:6	SHEET 5 OF 5
ENG APPR. -				